

- ① - Procedere al montaggio seguendo le operazioni in ordine numerico progressivo.
- Ⓒ - Proceed with assembling following the operations in progressive numerical order.
- Ⓓ - Arbeitsgänge in numerischer ordnung ausführen, um das gerät zu installieren.
- Ⓔ - Производите установку в порядке увеличения обозначенных выше номеров.
- Ⓕ - Il faut procéder a le montage exècutant les operatoins par l'ordre numerique progressif.
- Ⓖ - Proceder a montagem segundo as istruções em ordem numerica progressiva.
- Ⓔ - Proceder al montaje siguiendo las operaciones en orden numerico progresivo.

F32 M04A - F32 M06A - F32 M08A
F32 M10A

F32 M08

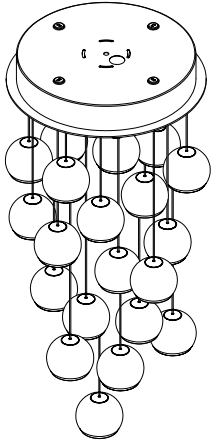

F32 M04

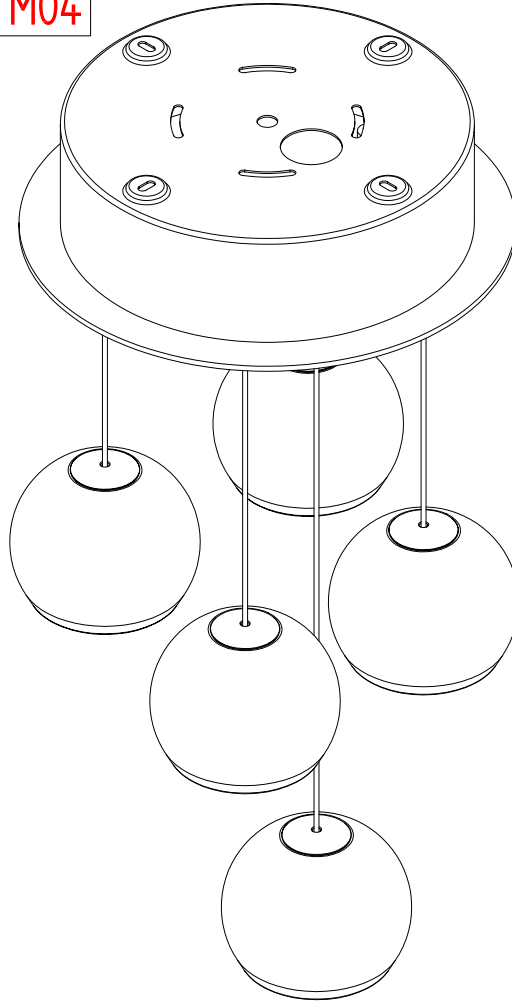

F32 M06

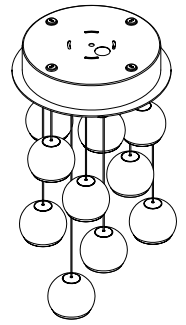

F32 M10

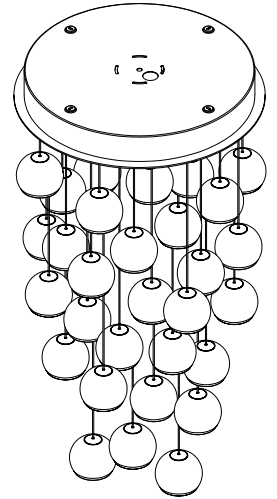

1

FASE 1: fissaggio plafone a soffitto
PHASE 1: box ceiling mounting

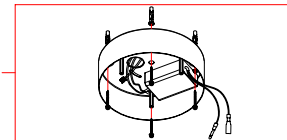

2

FASE 2: montaggio distanziatori
PHASE 2: spacers mounting

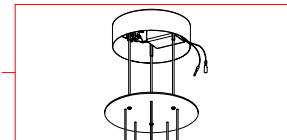

3

FASE 3: regolazione lunghezza cavi
PHASE 3: cable length adjustment

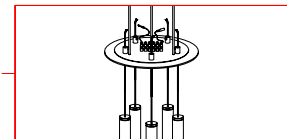

4

FASE 4: collegamento alla rete elettrica
PHASE 4: connection to the power

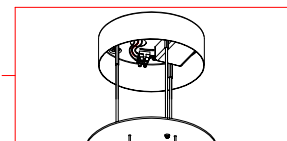

5

FASE 5: montaggio lampadine e vetri
PHASE 5: bulbs and glasses mounting

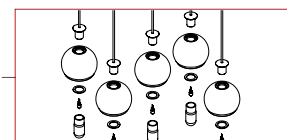

- ① - Procedere al montaggio seguendo le operazioni in ordine numerico progressivo.
- ⒸⒺ - Proceed with assembling following the operations in progressive numerical order.
- Ⓓ - Arbeitsgänge in numerischer ordnung ausführen, um das gerät zu installieren.
- Ⓔ - Производите установку в порядке увеличения обозначенных выше номеров.
- Ⓕ - Il faut procéder a le montage exècutant les operatoins par l'ordre numerique progressif.
- Ⓖ - Proceder a montagem segundo as instruções em ordem numerica progressiva.
- Ⓔ - Proceder al montaje siguiendo las operaciones en orden numerico progresivo.

F32 M04A - F32 M06A - F32 M08A
F32 M10A

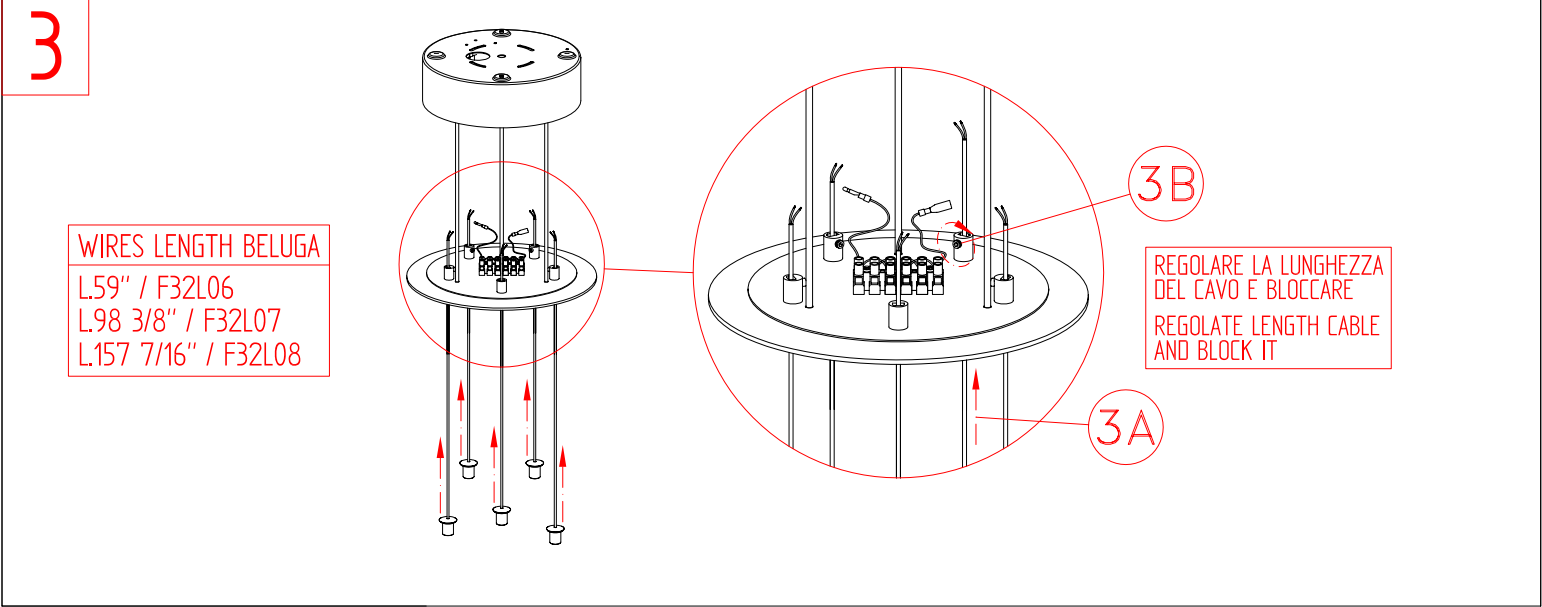
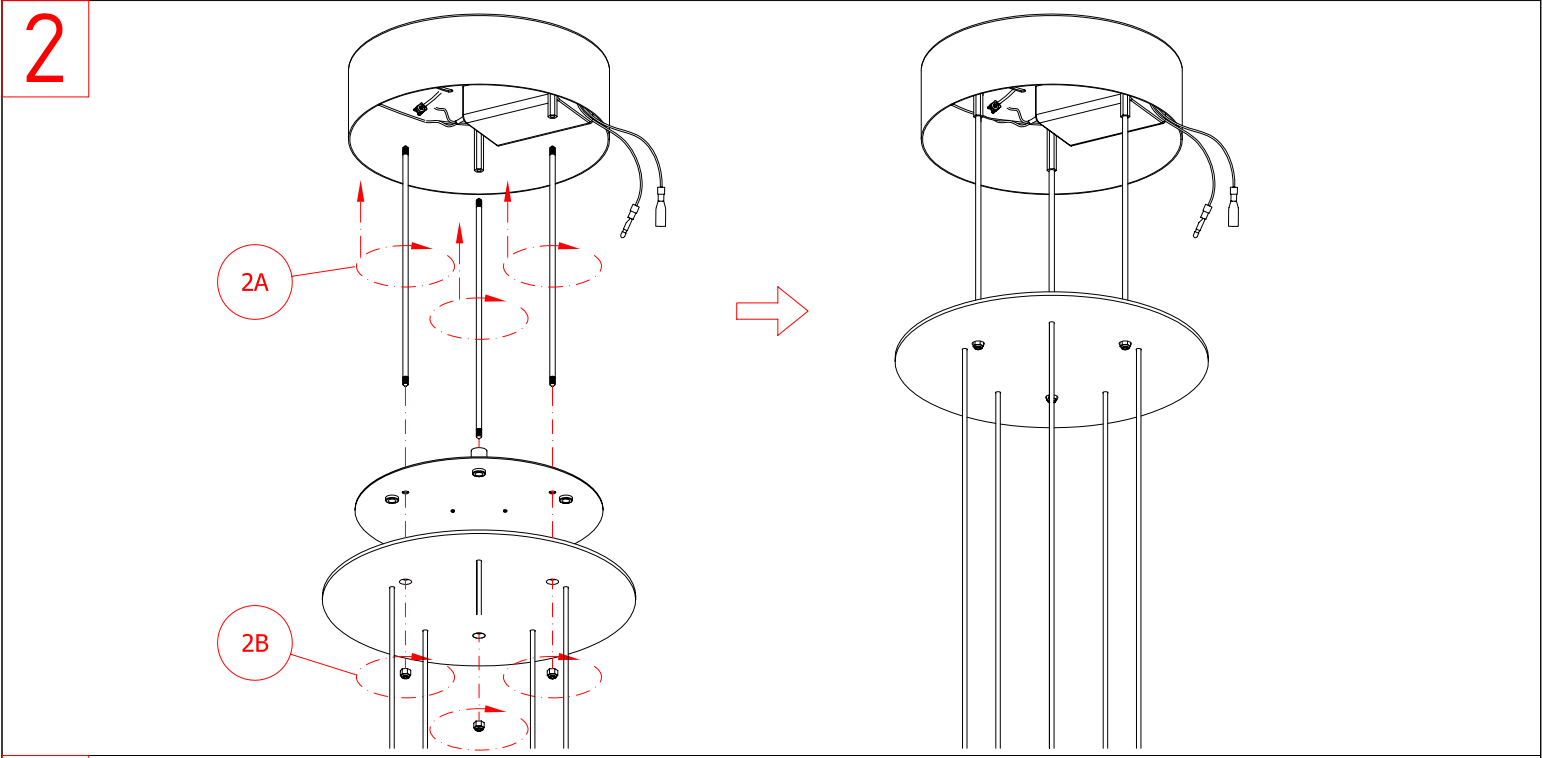
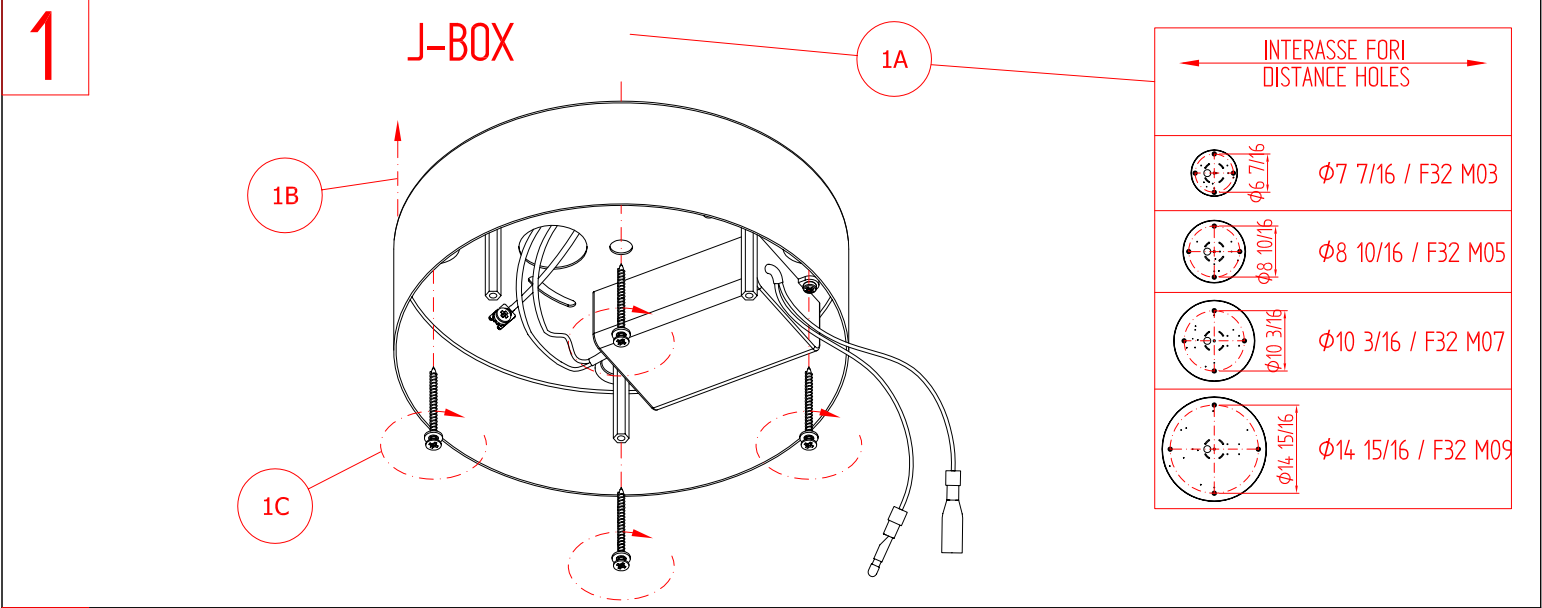

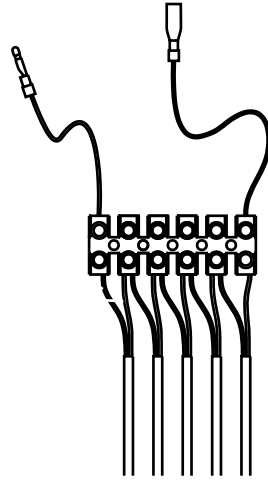

ATTENZIONE AL CAVO CALZA
DEL FARETTO NON DEVONO
TOCCARSI TRA LORO

ATTENTION TO SHIELD CABLE
SPOTLIGHTS MUST NOT
TOUCH EACH OTHER

ATTENZIONE AL BLOCCAGGIO
DEL CAVO NON DEVE ESSERE
MAGGIORE DI 0.25 Nm

ATTENTION TO THE LOCKING
OF THE CABLE MUST NOT BE
GREATER THAN 0.25 Nm

