

- I - Procedere al montaggio seguendo le operazioni in ordine numerico progressivo.
- GB - Proceed with assembling following the operations in progressive numerical order.
- D - Arbeitsgänge in numerischer Ordnung ausführen, um das Gerät zu installieren.
- RU - Производите установку в порядке увеличения обозначенных выше номеров.
- F - Il faut procéder a le montage exécutant les operatoins par l'ordre numerique progressif.
- P - Proceder a montagem segundo as instruções em ordem numerica progressiva.
- ES - Proceder al montaje siguiendo las operaciones en orden numerico progresivo.

F32 M23A-F32 M25A-F32 M27A  
F32 M29A - F32 M41A

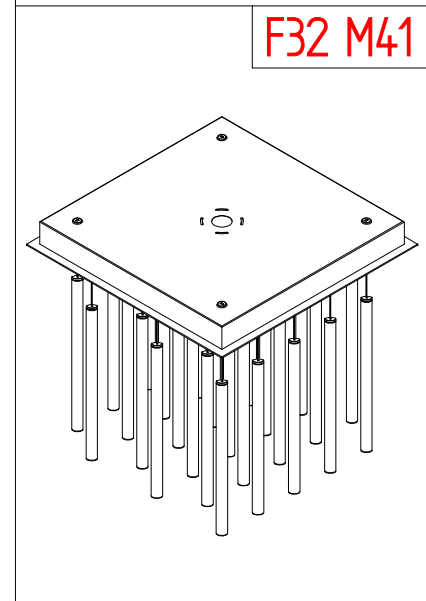

**1** FASE 1: *fissaggio plafone a soffitto*  
PHASE 1: *box ceiling mounting*

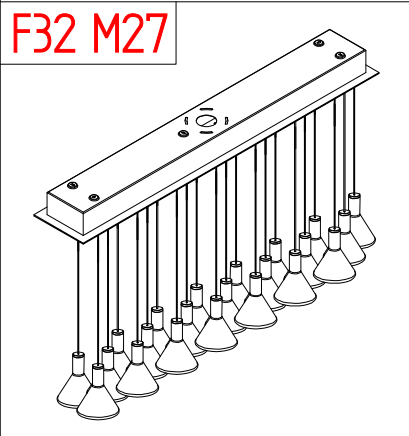
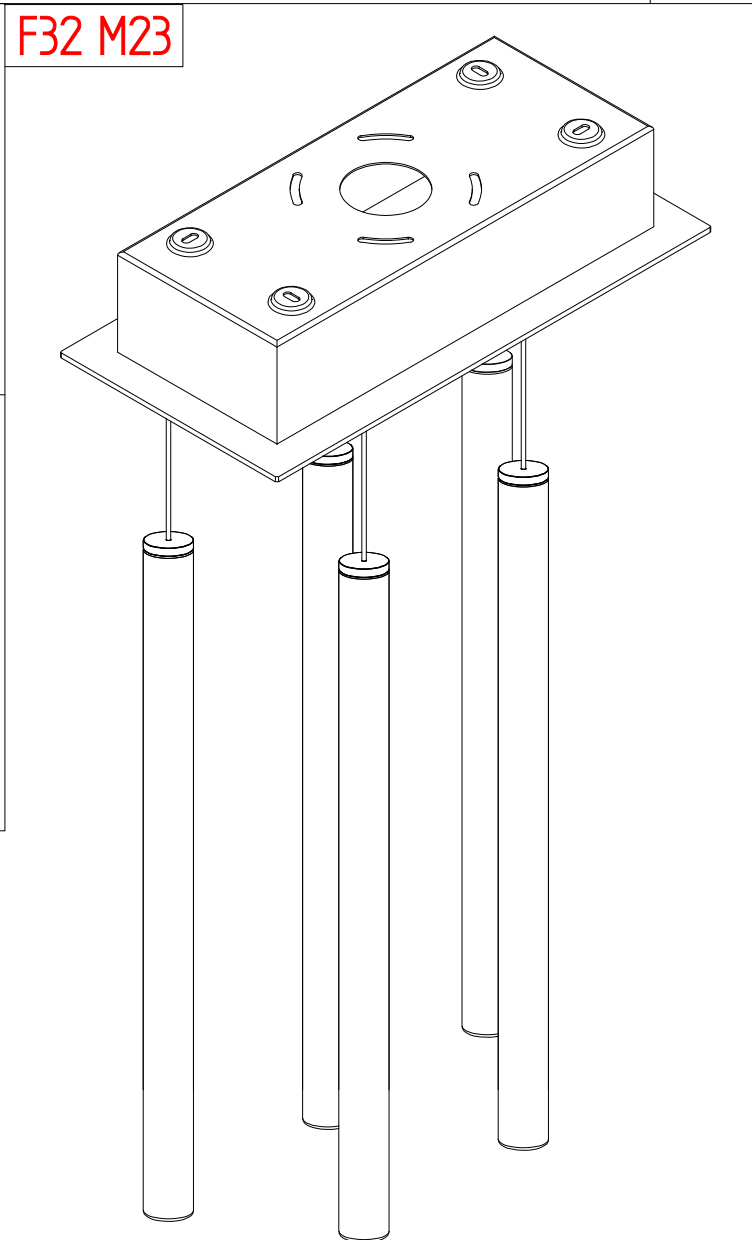
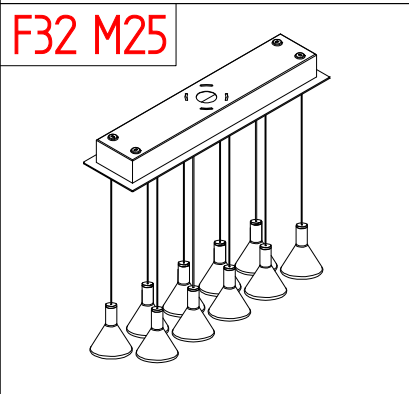
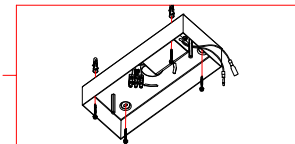

**2** FASE 2: *montaggio distanziatori*  
PHASE 2: *spacers mounting*

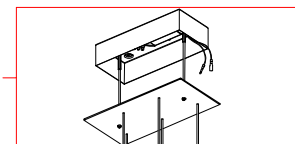

**3** FASE 3: *regolazione lunghezza cavi*  
PHASE 3: *cabl length adjustment*

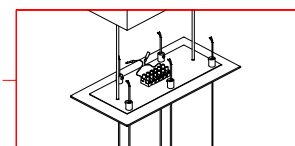

**4** FASE 4: *collegamento alla rete elettrica*  
PHASE 4: *connection to the power*

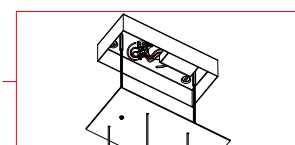

- I - Procedere al montaggio seguendo le operazioni in ordine numerico progressivo.
- GB - Proceed with assembling following the operations in progressive numerical order.
- D - Arbeitsgänge in numerischer ordnung ausführen, um das gerät zu installieren.
- RU - Производите установку в порядке увеличения обозначенных выше номеров.
- F - Il faut procéder a le montage exécutant les operatoins par l'ordre numerique progressif.
- P - Proceder a montagem segundo as instruções em ordem numerica progressiva.
- ES - Proceder al montaje siguiendo las operaciones en orden numerico progresivo.

# 1

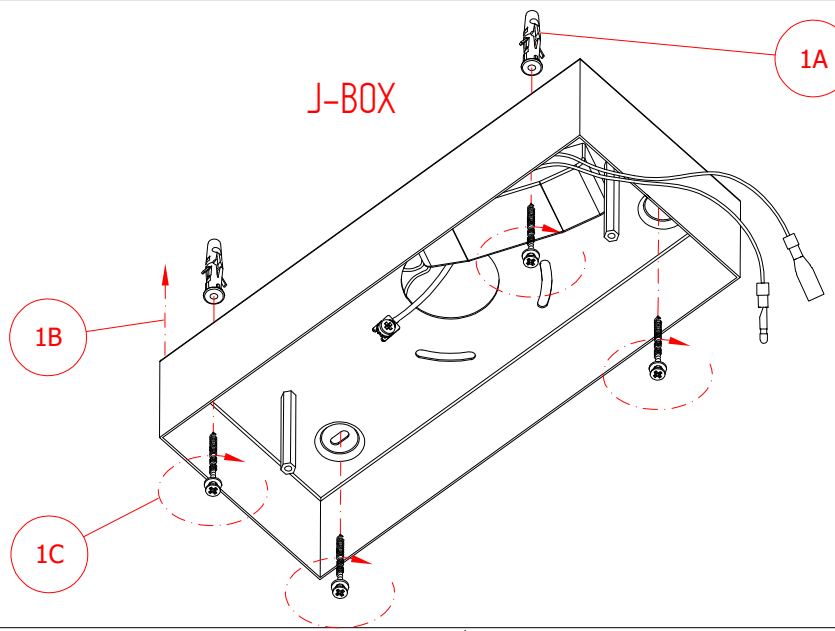

INTERASSE FORI DISTANCE HOLES	
	7 7/8"x2 3/4" / F32 M23
	19 11/16"x2 3/4" / F32 M25
	29 17/32"x2 3/4" / F32 M27 29 17/32"x2 3/4" / F32 M29
	17 21/64"x17 21/64" / F32 M41

# 2

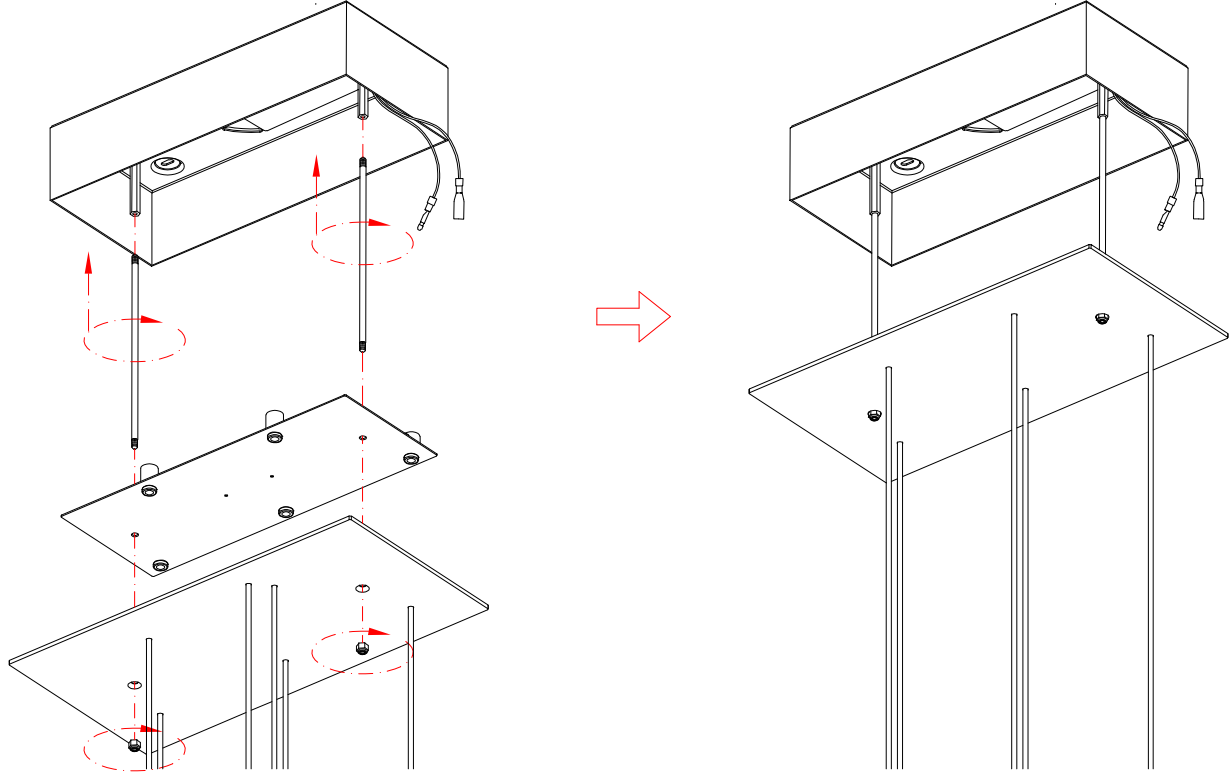

# 3

**WIRES LENGTH TOOBY**  
 L.59" / F32L01  
 L.98 3/8" / F32L02  
 L.157 7/16" / F32L03

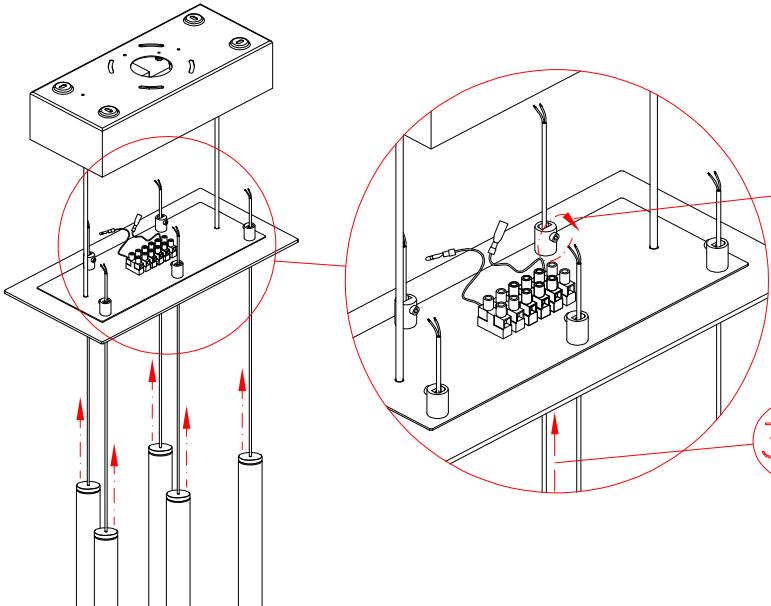

**REGOLARE LA LUNGHEZZA  
DEL CAVO E BLOCCARE**  
**REGULATE LENGTH CABLE  
AND BLOCK IT**

## F32 M23A-F32 M25A-F32 M27A F32 M29A - F32 M41A

- I - Procedere al montaggio seguendo le operazioni in ordine numerico progressivo.
- GB - Proceed with assembling following the operations in progressive numerical order.
- D - Arbeitsgänge in numerischer ordnung ausführen, um das gerät zu installieren.
- RU - Производите установку в порядке увеличения обозначенных выше номеров.
- F - Il faut procéder a le montage exécutant les operatoins par l'ordre numerique progressif.
- P - Proceder a montagem segundo as instruções em ordem numerica progressiva.
- ES - Proceder al montaje siguiendo las operaciones en orden numerico progresivo.

3C

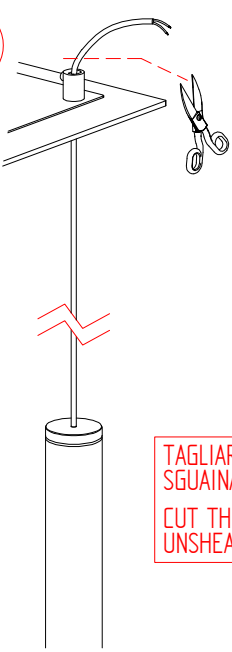

TAGLIARE IL CAVO E SQUAINARLO  
CUT THE CABLE AND UNSHEATHE IT

3D

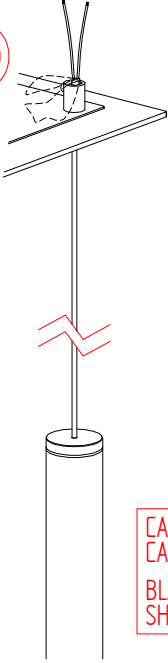

3E

COLLEGARE I CAVI ALLA MORSETTIERA  
CONNECT CABLES TO THE CLAMP

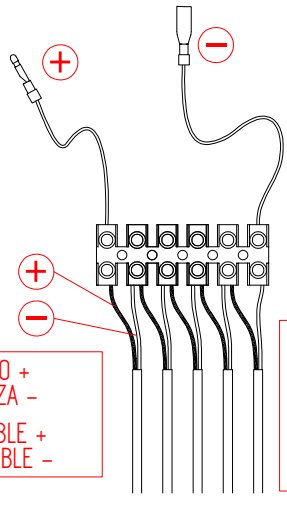

CAVO NERO +  
CAVO CALZA -  
BLACK CABLE +  
SHIELD CABLE -

ATTENZIONE AL CAVO CALZA DEL FARETTO NON DEVONO TOCCARSI TRA LORO  
ATTENTION TO SHIELD CABLE SPOTLIGHTS MUST NOT TOUCH EACH OTHER

ATTENZIONE AL BLOCCAGGIO DEL CAVO NON DEVE ESSERE MAGGIORE DI 0.25 Nm  
ATTENTION TO THE LOCKING OF THE CABLE MUST NOT BE GREATER THAN 0.25 Nm

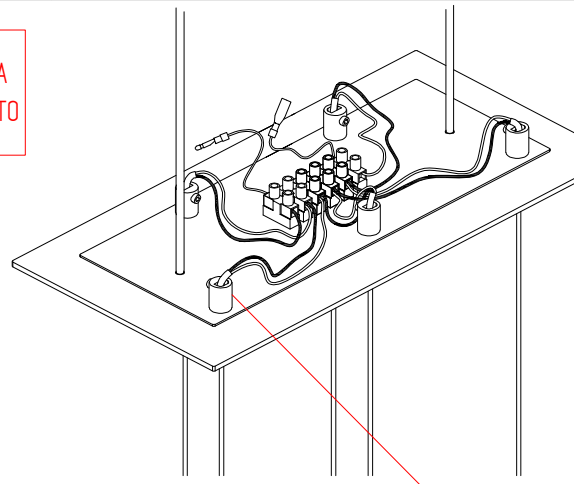

4a

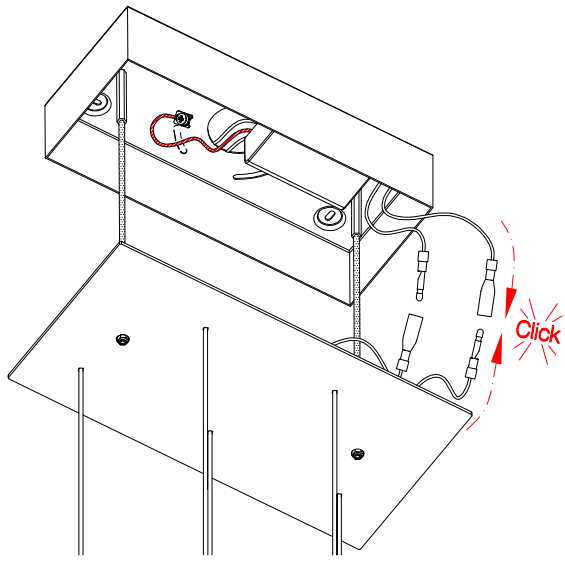

4b

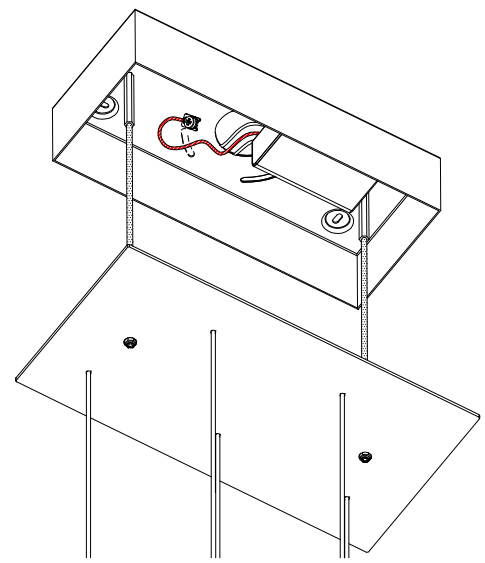

4c

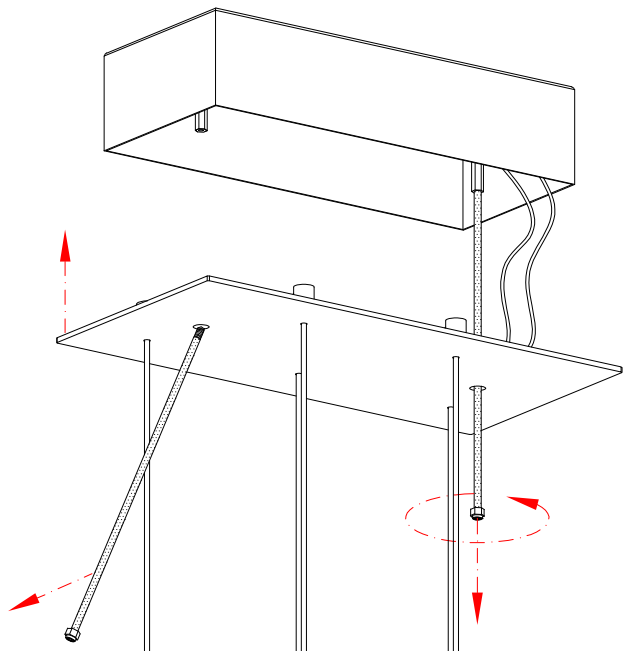

4d

